



**Blastrac bv**  
Utrechthaven 12  
3433 PN Nieuwegein  
Netherlands  
+31(0)30-6018866  
+31(0)30-6018333

Project description	854 ULCSA MKI		
Drawing number	PJ09.1079.02		
Blastrac number	E00076/ULCSA		
Power supply	480Y/277V 60Hz		
Input lead			
Control Voltage	24Vac		
Year of Manufacturing	2009		
Remarks	Released for construction		
Created on	18-6-2009	by	hvandenbrink
Edit date	9-9-2011	by	HvdB
			Number of pages 15





## WIRE COLOR

### All wiring AWG

#### Main Voltage

<u>Phase</u>	<u>Colors</u>
L1	- Black
L2	- Black
L3	- Black
Earth / PE	- Yellow/Green

#### Control Voltage 24Vac

Phase	- Red
Hook-up wire	- Red
Zero	- Red

## SYMBOL CODE

11 F 11

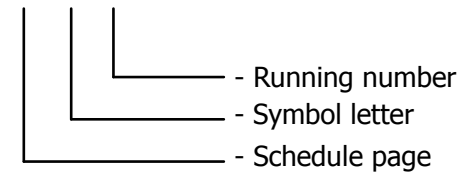

## CORE CODE

11 11

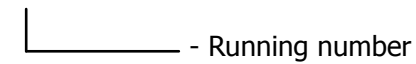

## DRAWING NUMBER

PJ##.####.##

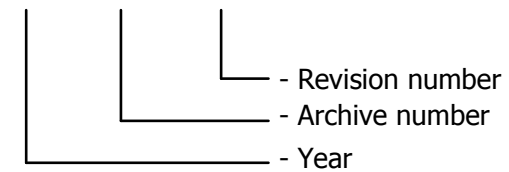

Date	11-5-2011	Project name:	854 ULCSA MKI	Page description:	Legend	Customer:	Blastrac bv	=
Ed.	HvdB		E00076/ULCSA			Drawing number:	PJ09.1079.02	+
Appr								Page
Modification	Date	Name	Last print	9-9-2011				3

	auxiliary contact	hulpcontact		signal light	signaallamp		Safety fuse	smeltveiligheid
	Power contact	vermogenscontact		horn	hoorn		Fused switch, three-pole	schakelbare scheid
	NO contact, opens with time delay	maakcontact, vertraagd open		apm.meter	amperemeter		Fused disconnect, three-pole	scheid "klappak"
	NO contact, closes with time delay	maakcontact, vertraagd sluitend		runninghour counter	urenteller		Main switch	hoofdschakelaar
	NC contact, opens with time delay	verbreekcontact, vertraagd open		transformer	transformator		Circuit breaker, single-pole	installatieautomaat 1-polig
	NC contact, closes with time delay	verbreekcontact, vertraagd sluitend		Contactor coil relay coil	spoel		Circuit breaker, two-pole	installatieautomaat 2-polig
	Pushbutton rebound	drukknop terugverend		Contactor/relay coil, with pick-up delay	Spoel met opkomvertraging		Circuit breaker, three-pole	installatieautomaat 3-polig
	Pushbutton locking	drukknop blijvend		Contactor/relay coil, with drop-out delay	spoel met afvalvertraging		Power circuit breaker motor overload switch with switch mechanism	motorbeveiligingsschakelaar
	Rotary switch rebound	tip draaischakelaar		Contactor pulse coil relay pulse coil,	spoel puls		Valve	elektrisch bediende klep
	Rotary switch locking	draaischakelaar		Tube light	TL verlichting		Resistor with movable contact	regelbare weerstand
	Emergency stop rotary unlock	noodstop met draaibare vrijgave		Resistor / Heating	weerstand verwarming		Terminal	rijgklem
	Thermostatic switch	thermostaat hygrostaat		Socket	wandcontactdoos		Terminal with fuse	rijgklem met zekering
	Pressure switch	drukschakelaar		Current transformer	stroomtransformator		Rectifier	gelijkrichter
	Limit switch	eindschakelaar						
	Proximity switch	naderingsschakelaar						

<table border="1"> <tr> <td>Date</td> <td>29-3-2011</td> </tr> <tr> <td>Ed.</td> <td>HvdB</td> </tr> <tr> <td>Appr</td> <td></td> </tr> <tr> <td>Last print</td> <td>9-9-2011</td> </tr> </table>				Date	29-3-2011	Ed.	HvdB	Appr		Last print	9-9-2011	Project name: <b>854 ULCSA MKI</b> E00076/ULCSA		Page description: Symbol library	Customer: <b>Blastrac bv</b>	=
Date	29-3-2011															
Ed.	HvdB															
Appr																
Last print	9-9-2011															
Modification	Date	Name			Drawing number: <b>PJ09.1079.02</b>	+										
						Page	<b>4</b>									

CABINET  
FRONT VIEW

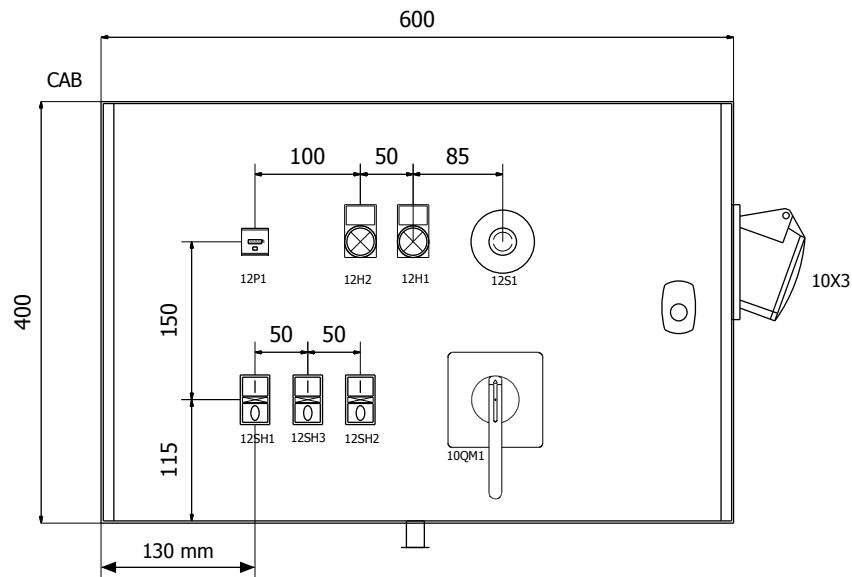

CABINET  
RIGHTHAND VIEW

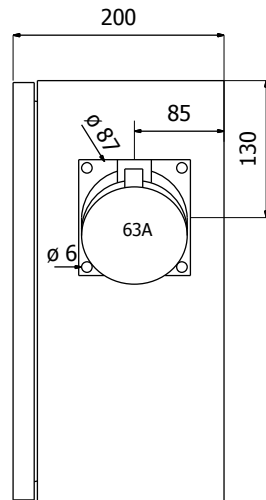

MOUNTING PLATE

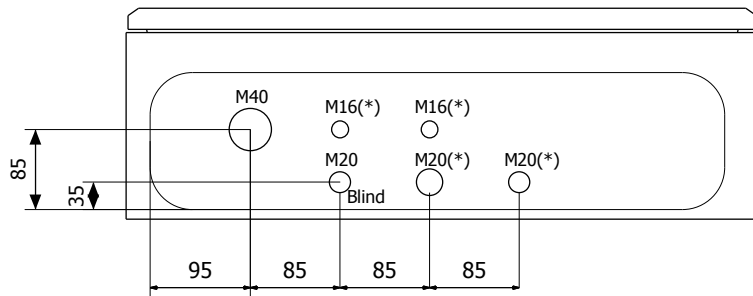
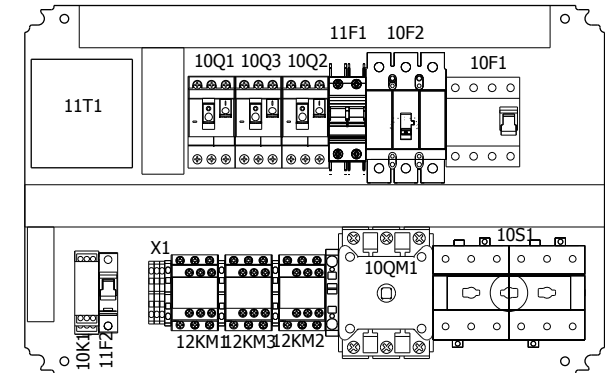

CABINET  
BOTTOM VIEW

- (\*): With cable
- M16 - Pulse system
- M16 - Earth wire connection to Frame
- M20 - Compressor motor
- M20 - Fan motor
- M20 - Blind
- M40 - Power supply

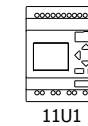

11U1

Date	12-8-2011
Ed.	HvdB
Appr	
Last print	9-9-2011

Project name:	854 ULCSA MKI E00076/ULCSA
---------------	-------------------------------



Page description:	Panel Layout
-------------------	--------------

Customer:	Blastrac bv
Drawing number:	PJ09.1079.02

Page	5
------	---

### Compressor (total length 2100mm)

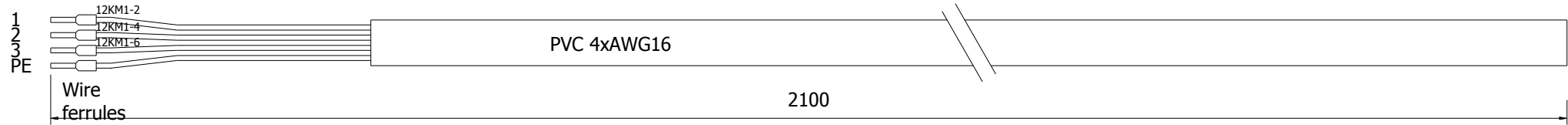

### Fan (total length 2100mm)

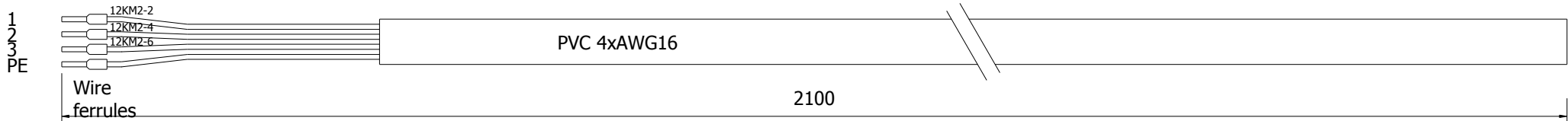

### Ultra Jet Unit (total length 3600mm)

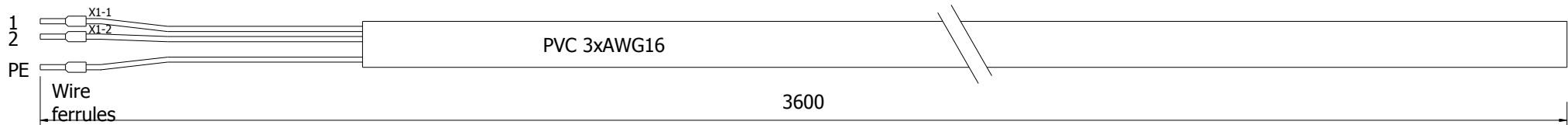

Date		4-8-2011		Project name:		854 ULCSA MKI		Page description:		Customer:		Blastrac bv	
Ed.						E00076/ULCSA		BLASTRAC		Cable Set		=	
Appr										Drawing number:		PJ09.1079.02	
Last print		9-9-2011										Page <b>6</b>	

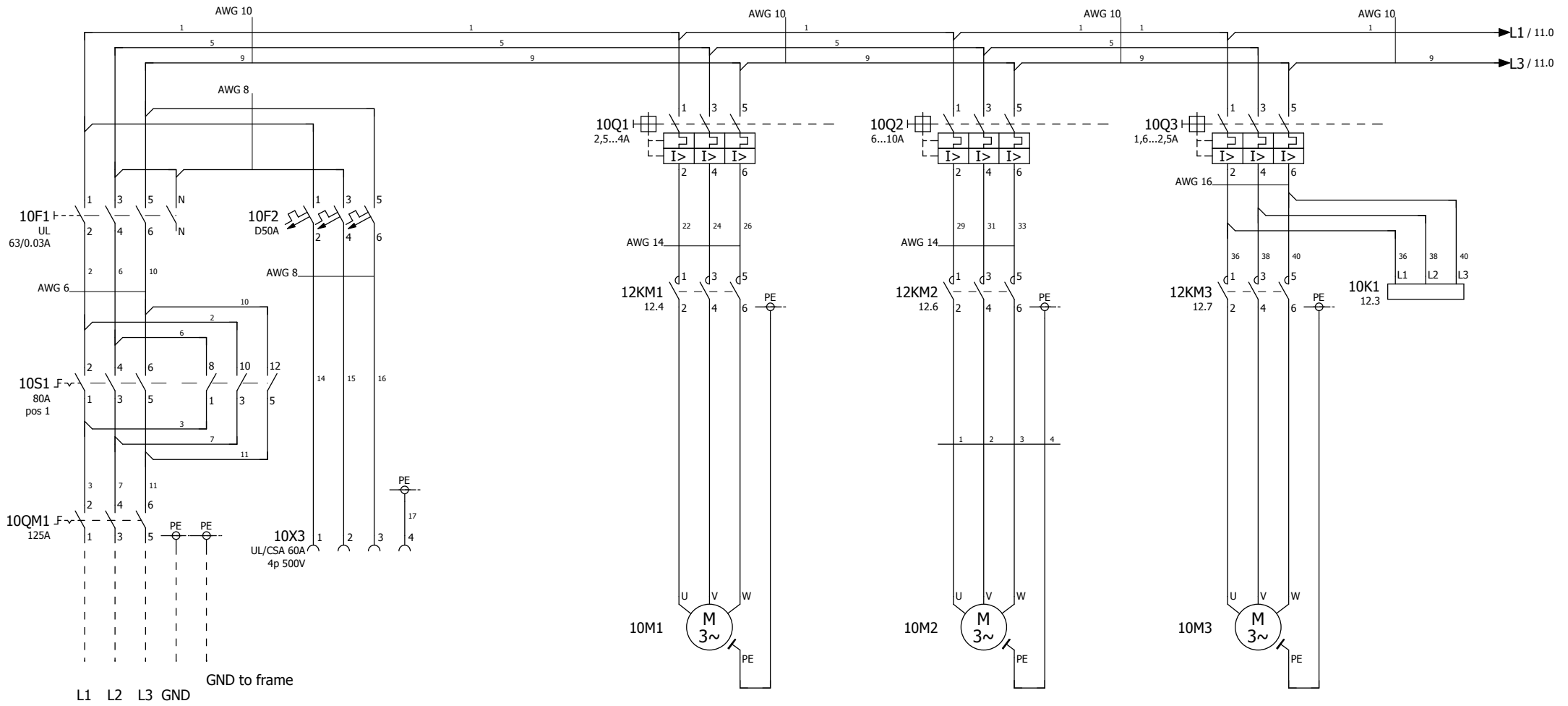

Supply  
480Y/277V 60Hz.

To blastrac  
machine  
480Y/277V, 50A, 32Hp

Compressor  
2Hp / 2,7A

Fan  
5Hp / 7,2A

Screw Conveyor  
1Hp / 1,8A

Phase sequence

Date		1-7-2011		Project name:		854 ULCSA MKI		Page description:		Customer:		=	
Ed.		HvdB				E00076/ULCSA		BLASTRAC		Blastrac bv		+	
Appr								Main current 480V 60Hz		Drawing number:		PJ09.1079.02	
Last print		9-9-2011										Page 10	
Modification	Date	Name	Last print										



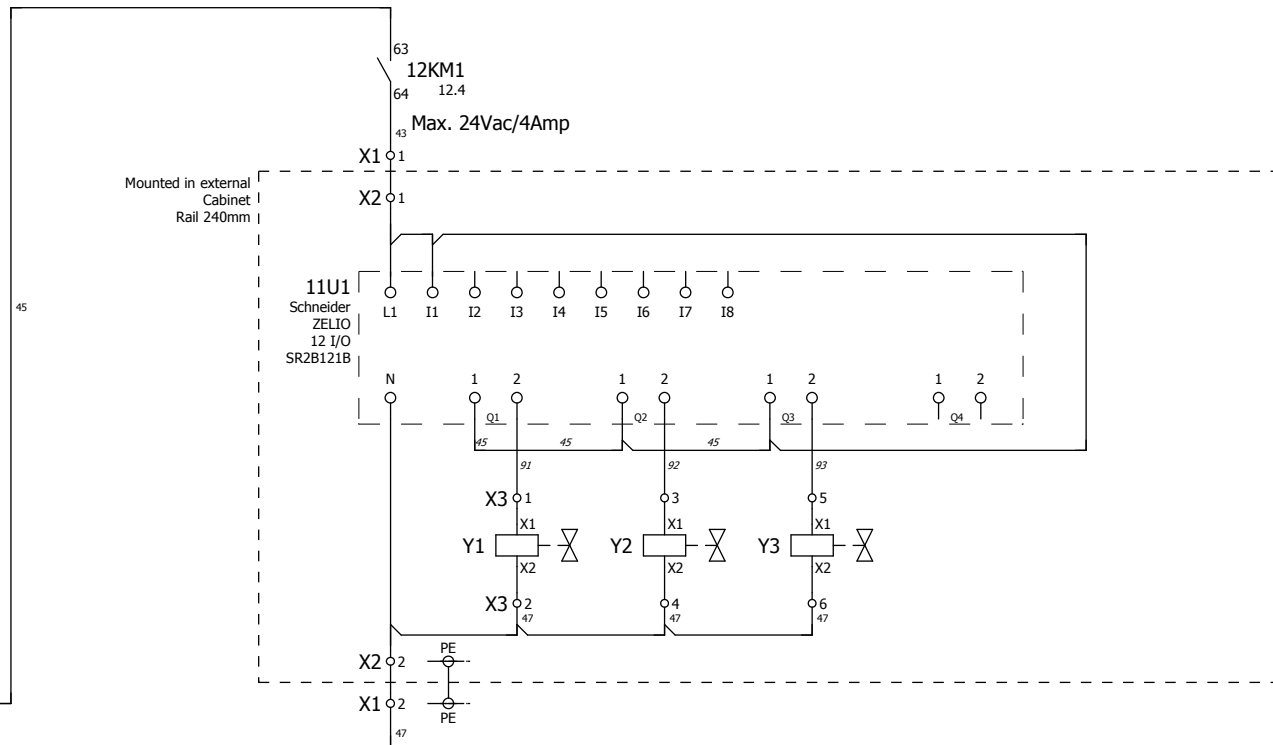
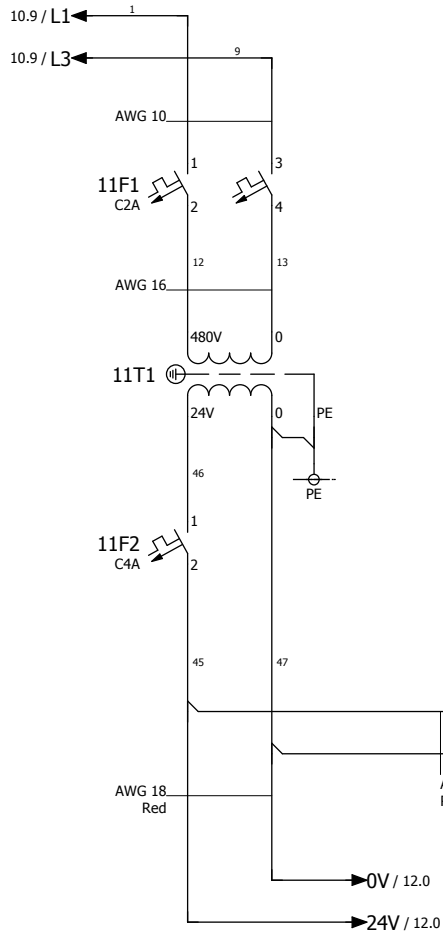

Puls Sequencer

Date	12-8-2011
Ed.	HvdB
Appr	
Last print	9-9-2011

Project name:	854 ULCSA MKI E00076/ULCSA
---------------	-------------------------------



Page description:	Main current 480V /220V 60Hz
-------------------	------------------------------

Customer:	Blastrac bv
Drawing number:	PJ09.1079.02

Page	11
------	----

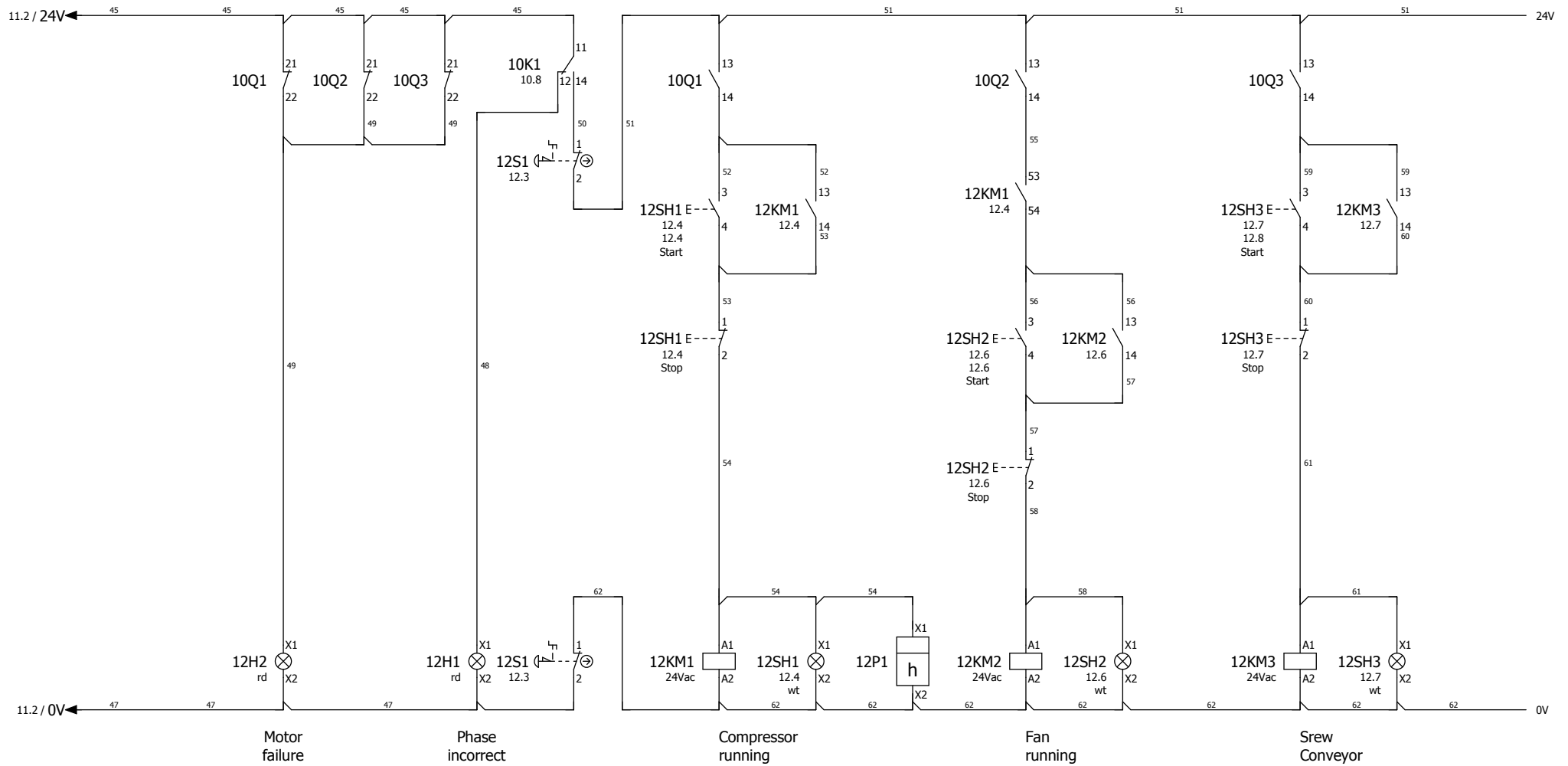

1 2 10.4  
 3 4 10.4  
 5 6 10.4  
 13 14 12.4  
 53 54 12.6  
 63 64 11.4

1 2 10.6  
 3 4 10.6  
 5 6 10.6  
 13 14 12.6

1 2 10.7  
 3 4 10.8  
 5 6 10.8  
 13 14 12.8

Date	9-9-2011
Ed.	HvdB
Appr	
Last print	9-9-2011

Project name:	854 ULCSA MKI E00076/ULCSA
---------------	-------------------------------



Page description:	Control current 24V
-------------------	---------------------

Customer:	Blastrac bv
Drawing number:	PJ09.1079.02
Page	12







# Parts list

device tag	Quantity	designation	Type number	Brand	Blastrac number
X1	1	Eindplaat Beige voor ZDU 2.5	WEID ZAP/TW 1	Weidmuller	E05168
X1	2	Steekklem 2*2.5 beige	WEID ZDU 2.5	Weidmuller	E05166
X1	2	Eindblok voor weidmuller klemmen	WEID ZEW 35	Weidmuller	E05177
X1	1	Aardklem voor ZDU 2.5 2*2.5(4)mm	WEID ZPE 2.5	Weidmuller	E05167
X2	1	Eindplaat Beige voor ZDU 2.5	WEID ZAP/TW 1	Weidmuller	E05168
X2	2	Steekklem 2*2.5 beige	WEID ZDU 2.5	Weidmuller	E05166
X2	1	Aardklem voor ZDU 2.5 2*2.5(4)mm	WEID ZPE 2.5	Weidmuller	E05167
X2	1	Eindblok voor weidmuller klemmen	WEID ZEW 35	Weidmuller	E05177
X3	1	Eindplaat Beige voor ZDU 2.5	WEID ZAP/TW 1	Weidmuller	E05168
X3	6	Steekklem 2*2.5 beige	WEID ZDU 2.5	Weidmuller	E05166
X3	1	Eindblok voor weidmuller klemmen	WEID ZEW 35	Weidmuller	E05177
10X3	1	Receptacle 60 A 3p+ground	UISV 4-60 US	Mennekes	E05067
CAB	1	Enclosure H400xW600xD200 IP66 RAL7035 with mount.plate.	NSYS3D4620P	Schneider Electric	E08021
CAB	5	Label for ZBY-5102 Brady 150pcs. p/r	PTLEP-04-7593-WT	Brady	E08113
CAB	200	Label for ader 12*12 Brady 7000pcs. p/r	BPT-305-427	Brady	E07893
CAB	2	Montagesnoer ge/gr. AWG10 6mm2 UL-CSA	AWG 10 GE/GR	LAPP	E07973
CAB	2	Montagesnoer zwart AWG10 6mm2 UL-CSA	AWG 10 ZW	LAPP	E07891
CAB	7	Montagesnoer zwart AWG14 2.5mm2 UL-CSA	AWG 14 ZWART	LAPP	E07843
CAB	1	Montagesnoer ge/gr. AWG16 1.5 mm2 UL-CSA	AWG 16 GN/GE	LAPP	E07975
CAB	4	Montagesnoer zwart AWG16 1.5mm2 UL-CSA	AWG 16 ZWART	LAPP	E07947
CAB	50	Montagesnoer rood AWG18 1.0mm2 UL-CSA	AWG 18 ROOD	LAPP	E07894
CAB	1	Montagesnoer zwart AWG6 16mm2 UL-CSA	AWG 6 ZWART	LAPP	E07948
CAB	2	Montagesnoer zwart AWG8 10mm2 UL-CSA	AWG 8 ZW	LAPP	E07867
CAB	5	Stuurstroomkabel pvc 4*1.5 UL/CSA+VDE	PVC OILFLEX 191 4*1.5	LAPP	E08022
CAB	4	Eszetflex pvc 3*1.5 mm UL/CSA 600V	H05VV5-F 3*1.5 MM	Eszet Electro	E08023
CAB	2	Cable gland M16*1.5 polyamide 50.616	WARTEL PA M16*1.5	Jacob	E01196
CAB	3	Cable gland M20*1.5 polyamide 50.620	WARTEL PA M20*1.5	Jacob	E07887
CAB	1	Cable gland M40*1.5 polyamide 50.640	WARTEL PA M40*1.5	Jacob	E07942
CAB	2	Cable gland nut M16*1.5 polyamide 50.216PA	WARTELMOER PA M16	Jacob	E07890
CAB	3	Cable gland nut M20*1.5 polyamide 50.220PA	WARTELMOER PA M20	Jacob	E07889
CAB	1	Cable gland nut M40*1.5 polyamide 50.240PA	WARTELMOER PA M40*1.	Jacob	E07943
10F1	1	Aardlek 63A 4-P 30mA UL/CSA ABB	F204-A63/0.03	Allen Bradley	E05068
10QM1	1	Rotary handle front KDF - for V5, V6 - red long handle	KDF-3PZ	Schneider Electric	E08024
10QM1	1	Door interlock V3..V6	KZ74	Schneider Electric	E00347
10QM1	1	Body 3p main switch 125A	V5	Schneider Electric	E00343
10QM1	1	SHAFT EXTENSION PIECE 300/350 MM	VZ18	Schneider Electric	E00346
10S1	1	faseomkeerschakelaar 6P 80A, bodem montage omkeerbaar	194E-A80-3753	Allen Bradley	E08025
10S1	1	Bed. draaisch. grijs/zwart voor 194L-E (48*48)	194L-HE4A-375	Allen Bradley	E05061-1
10F2	1	Molded Case Circuit Breaker 3P C50A UL489	AB 140U-G2C3-C50	Allen Bradley	E08146
10F2	1	DIN Rail Adapter fo MCCB 3P 140U-G2C3	AB 140U-G-DRA3	Allen Bradley	E08127
10Q1	1	Hulpcont. front voor GV2-ME 1xNO +1xNC	GV-AE11	Schneider Electric	333-3455
10Q1	1	Motor protection switch 2,4 4,0A	GV2-ME08	Schneider Electric	E01456
10Q2	1	Hulpcont. front voor GV2-ME 1xNO +1xNC	GV-AE11	Schneider Electric	333-3455
10Q2	1	Motor protection switch 6,0 10,0A	GV2-ME14	Schneider Electric	E05163
10Q3	1	Hulpcont. front voor GV2-ME 1xNO +1xNC	GV-AE11	Schneider Electric	333-3455
10Q3	1	Motor protection switch 1,6 2,5A	GV2-ME07	Schneider Electric	E01322
10K1	1	3-phase monitoring relays	DPA 01 C M44	Carlo Gavazzi	E07955
11F1	1	Zek. autom. AB 2P 2A C-kar UL 489 480/277V	C60N-1489-A2C020	Allen Bradley	E05159
11F2	1	Zek. autom. AB 1P 4A C-kar	C60N-1492-SP1C040	Allen Bradley	E05112
11T1	1	Transformer Sitas 160VA 480V 550..208V/24V UL/CSA	SIEM 4AM3842-8DN00-0EA0	Siemens	E07940
11U1	1	Compact smart relay Zelio Logic - 12 I O - 24 V AC - clock -	SR2B121B	Schneider Electric	E08171
11U1	1	Memory cartridge - for smart relay Zelio Logic firmware - fo	SR2MEM02	Schneider Electric	E08172
12H2	1	Red pilot light head Ø22 plain lens for integral LED	ZB5-AV043	Schneider Electric	E00360
12H2	1	Red light block with body/fixing collar integral LED 24V	ZB5-AVB4	Schneider Electric	E05072
12H2	1	Legend holder 30 x 50 mm for legend 18 x 27 mm unmarked	ZBZ-35	Schneider Electric	E05080
12H1	1	Red pilot light head Ø22 plain lens for integral LED	ZB5-AV043	Schneider Electric	E00360

Date		12-8-2011		Project name:		854 ULCSA MKI		Page description:		Customer:		Blastrac bv		=			
Ed.		HvdB				E00076/ULCSA		BLASTRAC		Parts list		Drawing number:		PJ09.1079.02		+	
Appr																Page	
Modification		Date		Name		Last print		9-9-2011								30	

# Parts list

device tag	Quantity	designation	Type number	Brand	Blastrac number
12H1	1	Red light block with body/fixing collar integral LED 24V	ZB5-AVB4	Schneider Electric	E05072
12H1	1	Legend holder 30 x 50 mm for legend 18 x 27 mm unmarked	ZBZ-35	Schneider Electric	E05080
12S1	1	Sticker noodstop rood/geel	NOODSTOPSTICKER	Generic	E07832
12S1	1	Red Ø40 Emergency switching off pushbutton head Ø22 latching	ZB4-B554	Schneider Electric	001398
12S1	1	Body for control button - Ø 22 - 2NC	ZB4-BZ104	Schneider Electric	E01333
12KM1	1	Auxiliary contact block - 2 NO - screw-clamps terminals	LAD-N20	Schneider Electric	500-3394
12KM1	1	Contacto 4,0kW 400VAC coil 24VAC 1NO/1NC	LC1-D09-B7	Schneider Electric	333-3580
12SH1	1	White light block with body/fixing collar integral LED 24V	ZB5-AVB1	Schneider Electric	333-3226
12SH1	1	Green flush/red flush illuminated double-headed pushbutton Ø	ZB5-AW7A3741	Schneider Electric	E07804
12SH1	1	Transparent boot for rectangular multiple-headed pushbutton	ZBA-710	Schneider Electric	E05070
12SH1	1	Single contact block for head Ø22 1NO screw clamp terminal	ZBE-101	Schneider Electric	E05091
12SH1	1	Single contact block for head Ø22 1NC screw clamp terminal	ZBE-102	Schneider Electric	E05092
12P1	1	Hour counter - mechanical 5 digit display - 12.24 V AC/DC	XB5-DSB	Schneider Electric	E00366
12KM2	1	Contacto 5,5kW 400VAC coil 24VAC 1NO/1NC	LC1-D12-B7	Schneider Electric	333-3452
12SH2	1	White light block with body/fixing collar integral LED 24V	ZB5-AVB1	Schneider Electric	333-3226
12SH2	1	Green flush/red flush illuminated double-headed pushbutton Ø	ZB5-AW7A3741	Schneider Electric	E07804
12SH2	1	Transparent boot for rectangular multiple-headed pushbutton	ZBA-710	Schneider Electric	E05070
12SH2	1	Single contact block for head Ø22 1NO screw clamp terminal	ZBE-101	Schneider Electric	E05091
12SH2	1	Single contact block for head Ø22 1NC screw clamp terminal	ZBE-102	Schneider Electric	E05092
12KM3	1	Contacto 4,0kW 400VAC coil 24VAC 1NO/1NC	LC1-D09-B7	Schneider Electric	333-3580
12SH3	1	White light block with body/fixing collar integral LED 24V	ZB5-AVB1	Schneider Electric	333-3226
12SH3	1	Green flush/red flush illuminated double-headed pushbutton Ø	ZB5-AW7A3741	Schneider Electric	E07804
12SH3	1	Transparent boot for rectangular multiple-headed pushbutton	ZBA-710	Schneider Electric	E05070
12SH3	1	Single contact block for head Ø22 1NO screw clamp terminal	ZBE-101	Schneider Electric	E05091
12SH3	1	Single contact block for head Ø22 1NC screw clamp terminal	ZBE-102	Schneider Electric	E05092